

SF ITAL



DESCRIPCIÓN TÉCNICA

- Parte estática del sello mecánico.
- Estacionaria con tórica.

MATERIALES

- Cerámica.
- Grafito.
- Carburo de silicio.
- Carburo de tungsteno (insertado en Inox).
- Carburo de tungsteno (integral).

Elastómeros: NBR, EPDM, VITÓN, AFLAS®, KALREZ®, CHEMRAZ®, etc.

COMPATIBILIDAD DE MATERIALES

Est. \ Rot.	Grafito	Cerámica	Inoxidable	Silicio	Tungsteno
Grafito	⊘	⊙	⊙	⊙	⊙
Cerámica	⊙	⊘	⊘	⊘	⊘
Inoxidable	⊙	⊘	⊘	⊘	⊘
Silicio	⊙	⊘	⊘	⊙	⊙
Tungsteno	⊙	⊘	⊘	⊙	⊙

⊙ Compatible ⊘ No compatible

Dimensiones

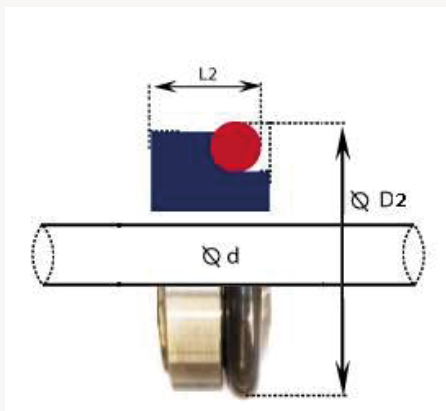

Ø d	D2	L2	Ø d	D2	L2
10	18.1	5.5	35	53.5	11.5
11	20.6	5.5	38	60.5	11.5
12	20.6	5.5	40	60.5	11.5
13	23.1	6.0	42	60.5	11.5
14	23.1	6.0	43	60.5	11.5
15	26.9	7.0	45	65.5	11.5
16	26.9	7.0	48	65.5	11.5
17	26.9	7.0	50	72.5	11.5
18	30.9	8.0	53	72.5	11.5
19	30.9	8.0	55	72.5	11.5
20	30.9	8.0	60	79.3	11.5
22	35.4	8.0	65	84.5	11.5
24	35.4	8.0	70	89.5	11.5
25	38.2	8.5	75	94.5	11.5
28	43.3	9.0	80	99.5	11.5
29	43.3	9.0	85	105.5	13.5
30	43.3	9.0	90	111.5	13.5
32	43.3	9.0	95	116.5	13.5
33	53.5	11.5	100	119.5	13.5

Dimensiones en Milímetros

Los componentes y las especificaciones pueden cambiar sin previo aviso. Otras medidas se suministran bajo pedido.